



RILEM TC 176-IDC INTERNAL DAMAGE OF CONCRETE DUE TO FROST ACTION

Recommendations of RILEM TC 176-IDC: Test methods of frost resistance of concrete

The tests presented hereafter are drafts for general consideration. Comments should be sent to the TC Chairman: M. J. Setzer, University of Essen, IBPM - Institute of Building Physics and Material Science, Postfach 45117 Essen, Germany; email: mj.setzer@uni-essen.de, by 30 April 2002.

Remarks by the Chairman of RILEM TC 176-IDC:

I. Formal decisions:

The RILEM TC 176-IDC decided at its meetings in Bergamo (2000), Paris (2000) and Essen (2001):

1. Two test procedures shall be published as RILEM Recommendations:

CIF-test and modified Slab test.

The CIF test extends the existing RILEM Recommendation CDF test¹ which was developed for measuring the scaling under the attack of frost and de-icing agents.

The modified Slab test relies on the Swedish Standard SS137244.

2. The tests are presented to give a basis for gaining experience.

3. The descriptions shall be based on proposals already distributed to the Committee.

4. Responsible authors are for CIF-Test M. J. Setzer and for Slab-Test Per-Erik Petersson and Luping Tang.

5. Two inter-laboratory-tests have been performed by RILEM TC 176-IDC in 2000 – one for CIF and one for modified Slab test, each comprising three concretes. The results have been evaluated strictly basing on ISO 5725 by Dr. Auberg and Mrs. Kasperek for CIF and by Dr. Luping Tang for modified Slab test. The results have been cross-checked by the two groups. The RILEM TC 176-IDC decided to use these precision data for the drafts.

II. Comments by the Chairman:

1. It must be taken into account that the results and especially the level of damage is different in both tests. Therefore, it is not appropriate to compare the simple number even if similar physical parameters are used such as transit time, dynamic elastic modulus and relative length change. Based on the inter-laboratory test, the measured damage can be up to a factor of 3 higher in CIF than in modified Slab test.

2. The damage levels given in the precision tables are not to be mistaken as acceptance criteria. The RILEM TC 176-IDC is not prepared at this time to propose acceptance criteria. Acceptance criteria are in the responsibility of contractors committees of standardization. For this, additional data which link the test results with performance under practical conditions are necessary (such conditions can vary considerably based on local and regional climatic conditions).

MEMBERSHIP: Chairman: M. J. Setzer; **Secretary:** D. J. Janssen; **Voting Members:** R. Auberg, Germany; D. H. Bager (Denmark), G. Gudmundsson (Iceland), S. Jacobsen (Norway), H. Kukko (Finland), T. Miura (Japan), H. Mihashi (Japan), V. Penttala (Finland), P.-E. Petersson (Sweden), E. Schulson (USA), J. Stark (Germany), L. Tang (Sweden), P. Ursella (Italy)

Slab Test - Freeze/Thaw Resistance of Concrete – Internal deterioration

Prepared by L. Tang and P.-E. Petersson

1. SCOPE AND APPLICATIONS

This method is used for determining the resistance of concrete to internal deterioration when subjected to repeated freezing-and-thawing. 3.0% NaCl solution is used as a freezing medium for concrete in an environment with de-icing salt, and demineralized water is used as a freezing medium for concrete in an environment without de-icing salt.

2. EQUIPMENT

Saw with a diamond edge for concrete cutting.

Climate chamber 20 (\pm 2) $^{\circ}$ C, 65 (\pm 5)% RH.

Evaporation in the climate chamber from a free water surface is to be 45 (\pm 15) g/m²/hr. Evaporation is measured from a vessel with a depth of 40 (\pm 2) mm and a surface of 225 (\pm 25) cm². The vessel is to be filled with water up to 10 (\pm 1) mm from the edge.

Freezing chamber with temperature and time controlled refrigerating and heating system with a capacity such that the time-temperature sequence presented in Fig. 8 can be followed. There should be good air circulation in the freezing chamber.

Thermo-element or the equivalent to measure the temperature in the freezing medium on the freeze surface, with an accuracy of \pm 0.5 $^{\circ}$ C.

Spray bottle containing tap water for rinsing off scaled material.

Venier calliper with the accuracy ± 0.1 mm.

Scale with the accuracy ± 0.1 g (optional for the measurement of scaled materials and specimen weight, if required).

Three-point expansometer (for the reference procedure, see Chapter 5) with an accuracy within ± 0.01 mm.

Ultrasonic equipment (for the alternative procedure A, see Chapter 6) with the accuracy ± 0.2 μ s and a couple of 50~60 kHz conic transducers.

Fundamental frequency equipment (for the alternative procedure B, see Chapter 6) with an accelerometer of about 7 mm diameter. The accelerometer should be less than 2 grams and have a flat (adhesive) base. The reasonable sensitivity of the accelerometer would be in the range of 10 mV/g of acceleration.

3. CONSUMABLE MATERIALS

Self-adhesive paper labels with a diameter of 12~14 mm, water-based glue.

Rubber cloth 3 (± 0.5) mm thick, for sealing all sides of the specimen except the test surface. The rubber cloth is to be resistant to the freezing medium used and should have adequate elasticity down to a temperature of -20°C .

Contact adhesive for gluing the rubber cloth to the concrete specimen. The adhesive is to be resistant to the environment in question.

Self-adhesive poly-labels with a suitable size for marking the measurement positions on the rubber cloth (for the reference procedure only). The labels are to be resistant to the environment in question.

Polystyrene cellular plastic 20 (± 1) mm thick and with a density of 18 (± 2) kg/m^3 or, alternatively, insulating material with equivalent properties.

Polyethylene film at least 0.1 mm thick.

Freezing medium consisting either of 97.0% by weight tap water and 3.0% by weight NaCl (for the concrete used in an environment with de-icing salt), or of demineralized water (for the concrete used in an environment without de-icing salt).

4. PREPARATION OF TEST SAMPLES

4.1 Concrete specimen

Four specimens from four cubes should be tested as one series.

Four 150 mm cubes are cast and compacted on a vibrating table in accordance with the procedure described in pr EN-ISO 2736/2-1993.

During the first day after casting the cubes are stored in the moulds at an air temperature of 20 (± 2) $^{\circ}\text{C}$, prevented from drying by covering with a plastic sheet.

After 24 (± 2) hours the cubes are removed from the moulds and placed in a tap water bath with a temperature of 20 (± 2) $^{\circ}\text{C}$.

When the cubes are 7 days old they are removed from the water bath and are stored in a climate chamber

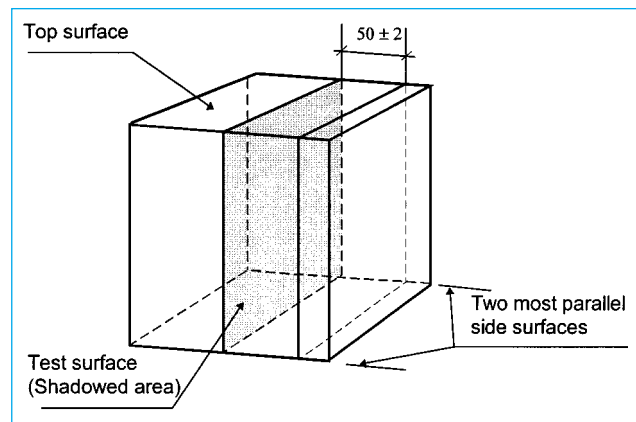

Fig. 1 – Illustration of sawing of a specimen.

at the air temperature 20 (± 2) $^{\circ}\text{C}$ and the relative humidity 65 (± 5)%. Furthermore, in the climate chamber the evaporation rate from a free water surface shall be kept within 45 (± 15) $\text{g}/\text{m}^2/\text{hr}$. This is normally obtained with a wind velocity < 0.1 m/s. The evaporation rate shall be measured according to the procedure described in Chapter 2 - Equipment.

At an age of 21 days, a 50 (± 2) mm thick slab is sawn from each cube perpendicular to the top surface and the two most parallel side surfaces, so that one cut surface is located in the centre of the cube and becomes the test surface. Sawing is illustrated in Fig. 1.

Directly after sawing the specimen is washed with tap water, the excess water is wiped off with a moist sponge and then the specimen is returned without delay to the climate chamber. The specimens shall be placed with the test surface vertically exposed to the air. The space between specimens shall be at least 50 mm. The side lengths of each specimen shall be measured with an accuracy of ± 0.5 mm by using Venier callipers. The variation in thickness of a specimen shall not exceed 1 mm.

4.2 Gluing of rubber cloths

Mark on the two most parallel side surfaces the points for the reference measurement procedure or the alternative measurement procedure A, as shown in Fig. 2. Notice that the selected points should be free of voids and defects. Protect the points with $\text{Ø}12\sim 14$ mm paper labels. Cut a 150 \times 150 mm square rubber cloth and a 630 \times 73 mm rectangular rubber cloth for each specimen. Evenly apply the adhesive to both the rubber cloths and the concrete surfaces except the test surface. Glue the square cloth to the surface opposite to the test surface of the specimen. Glue the rectangular cloth to the side surfaces remembering the positions with the marked points. After gluing, an additional fillet of glue is applied around the test surface, in the corner between the rubber cloth and the concrete, as shown in Fig. 3. The edge of the rubber cloth shall reach 20 (± 1) mm above the level of the test surface, see Fig. 3. Punch $\text{Ø}12\sim 14$ mm holes through the rectangular cloth at the positions with the marked points. Remove the paper labels from the marked points and return the specimens

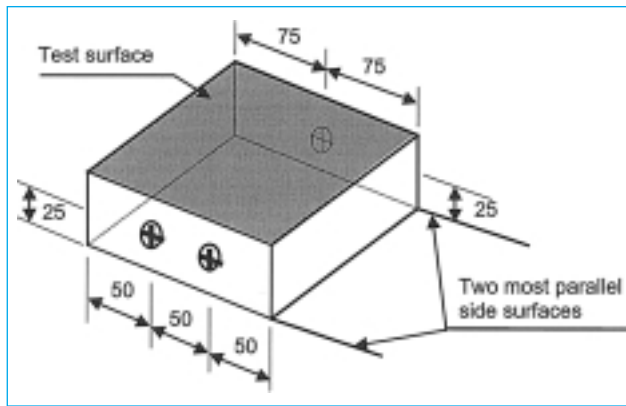

Fig. 2a - Illustration of the marks for the reference procedure.

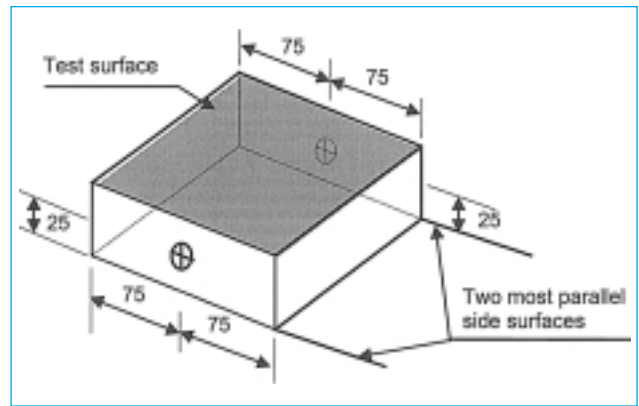

Fig. 2b - Illustration of the marks for the alternative procedure A.

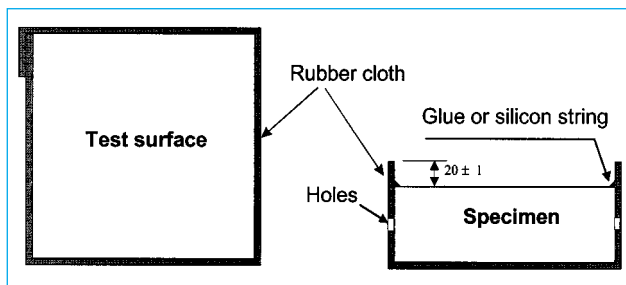

Fig. 3 - Specimen after gluing of rubber cloth (left - a top view, right - a side view).

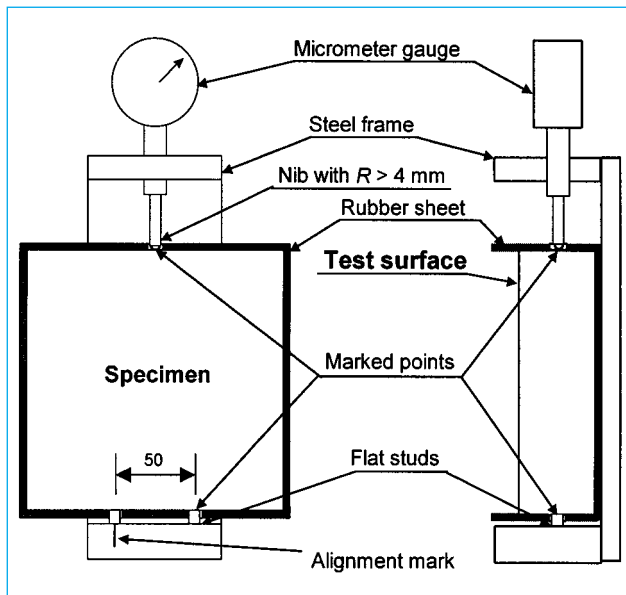

Fig. 4 - Specimen on the three-point expansometer.

without delay to the climate chamber with the test surface horizontally exposed to the air.

4.3 Pre-wetting of the specimen

At the age of 28 days, pour an approximately 3 mm thick layer of demineralized water at a temperature of $20 (\pm 2)^\circ\text{C}$ onto the test surface. This pre-wetting condition shall last for $72 (\pm 2)$ hours at $20 (\pm 2)^\circ\text{C}$. It has been found that for

specimens with the test area of 150×150 mm, 67 ml water gives an approximately 3 mm thick layer.

5. REFERENCE PROCEDURE FOR MEASUREMENT OF INTERNAL DAMAGE

The measurement shall be carried out at room temperature. Calibrate the expansometer with a reference steel block of $150 (\pm 0.02)$ mm long. Place the specimen on to the expansometer with the test surface outwards faced, see Fig. 4. Align the two marked points on one side of the specimen to the two studs on the expansometer. Care should be taken to assure good contact between the stud and concrete surface. Sticking a poly-label on to the rubber cloth can facilitate the alignment. Hold the specimen together with the expansometer vertically standing and assure that the measurement nib of the micrometer is in contact with the opposite side of the specimen where there is another marked point. Read the micrometer to the nearest 0.01 mm.

6. ALTERNATIVE PROCEDURES FOR MEASUREMENT OF INTERNAL DAMAGE

Two alternative procedures can be used: 1) ultrasonic pulse transmission time (UPTT) measurement and 2) fundamental frequency (FF) measurement. The measurement shall be carried out at room temperature.

6.1 Alternative A - UPTT measurement

Prepare and calibrate the apparatus according to the manufacturer's instructions. Position the transducers such as shown in Fig. 5. Apply a small amount of sonic



Fig. 5 - Illustration for the UPTT measurement (a side view).

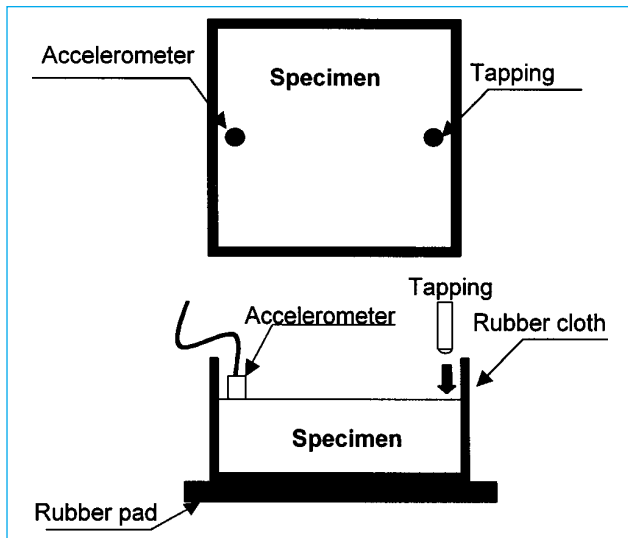

Fig. 6 – Illustration for the FF measurement (upper – a top view, lower – a side view).

conductive grease on the marked points. Press the transducers against the concrete surfaces so that a constant minimum value is reached. Read the transmission time to the nearest 0.2 μ s.

6.2 Alternative B - FF measurement

Prepare the apparatus according to the manufacturer’s instructions. The transverse mode of testing is recommended for measurements producing the least variation in results for this size of specimen. The test specimen should be placed on a thick pad of sponge rubber. The accelerometer is attached to the specimen at the position as shown in Fig. 6. Hold the accelerometer by hand or by another suitable means, such as a rubber band, and tap the specimen using a suitable tool (preferably an instrumented hammer) at the position as shown in Fig. 6. A small metallic plate could be used to protect a weak concrete surface at the tapping position from damage caused by tapping. Record the FF to the nearest 10 Hz. Repeat the tapping at least three times to obtain an average value of FF with a standard deviation less than 100 Hz (or 200 Hz for severely deteriorated concrete).

7. FREEZING-AND-THAWING TEST

When the concrete is 31 days old, that is, after the 72-hour pre-wetting, remove the water from the test surface. Measure the initial value of the length of each specimen according to the procedure described in Chapter 5. Alternatively, measure the UPTT or the fundamental frequency of each specimen according to the procedures described in Chapter 6. Immediately after the measurement pour 67 ml freezing medium at $20 (\pm 2)^\circ\text{C}$ onto the test surface so that an average 3 mm thick liquid layer is achieved above the test surface. Then insulate all the surfaces of the specimens (with the exception of the freeze surface) with $20 (\pm 1)$ mm thick polystyrene cellular plas-

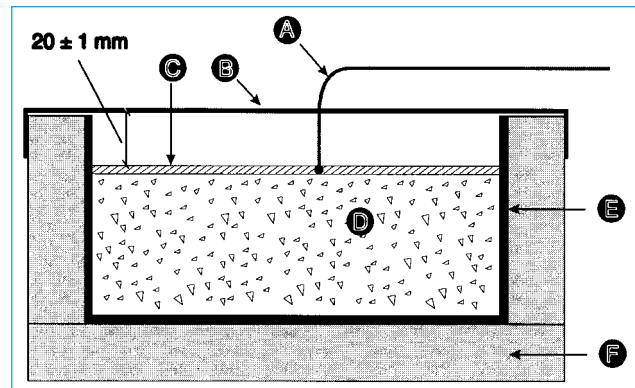

Fig. 7 – Test set-up. A = Thermo-element, B = Evaporation protection, C = Freezing medium, D = Specimen, E = Rubber cloths, F = Thermal insulation.

tic. The duration from water removal to the completion of pouring the freezing medium shall be no longer than 15 minutes. Shortly after pouring freezing medium (no longer than 15 minutes) the specimens shall be placed in the freezing chamber for the freezing-and-thawing test.

The freezing medium is, depending on the test purpose: 3 % NaCl solution for the concrete used in an environment with de-icing salt, or demineralised water for the concrete used in an environment without de-icing salt. The freezing medium shall be prevented from evaporation with a thick polyethylene film as shown in Fig. 7. The test set-up shall be kept horizontal and the polyethylene film shall remain flat throughout the whole test.

The specimens after having been placed in the freezing chamber shall be subjected to repeated freezing and thawing. During the test the temperature in the freezing medium for all specimens shall follow the regime specified in Fig. 8. The temperature in the freezing medium at the centre of the test surface shall be continuously recorded for at least one specimen in each freezing chamber. For a freezing chamber that is continuously running, the specimens shall be placed in the chamber at the point of time 0 (± 0.5 hours) according to the regime shown in Fig. 8.

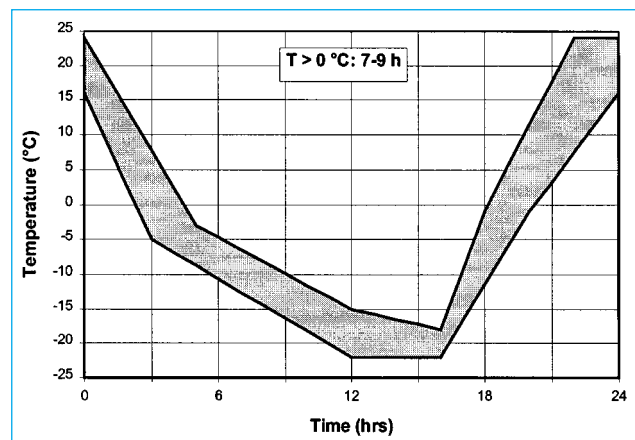

Fig. 8 – Temperature regime for one cycle of freezing-and-thawing. The temperature in the freezing medium at the centre of the test surface shall be within the shaded area and shall exceed 0°C for at least 7 hours but no more than 9 hours during each cycle.

Table 1 – Breaking points for the upper and lower limits of the temperature regime					
Upper limit		Lower limit		Mean curve	
Time, hrs	Temp., °C	Time, hrs	Temp., °C	Time, hrs	Temp., °C
0	+24	0	+16	0	+20
5	-3	3	-5	4	-4
12	-15	12	-22	12	-20
16	-18	16	-22	16	-20
18	-1	20	-1	20	+20
22	+24	24	+16	24	+20

The breaking points for the upper and lower limits of the temperature regime are given in Table 1.

To obtain the correct temperature cycle for all the specimens, there must be good air circulation in the freezing chamber. The number of specimens in the chamber should always be the same. If only a few specimens are tested the empty places in the freezing chamber shall be filled with dummies, unless it has been proven that the correct temperature can be achieved regardless of the number of specimens.

After 7, 14, 28, 42 and 56 cycles (also 70, 84, 98 and 112 cycles in the case of extended testing), the following procedure shall be carried out for each specimen during the thawing phase at the time 20–24 hours according to the temperature regime (see Fig. 8):

a) Pour away the excess freezing medium and wash away the scaled material*, if there is any, from the test surface with tap water using a spray bottle.

b) Measure the length, UPTT or FF of the specimen depending on which procedure has been used in the measurement for the initial values.

c) Pour new freezing medium onto the test surface in the same quantity as previously (e.g., 67 ml for 150 × 150 mm test area).

d) Return the specimen to the freezing chamber at the point of time 0 (± 0.5 hours) according to the regime shown in Fig. 8.

The duration from procedure a) to procedure c) should not be longer than 15 minutes for each specimen.

8. EXPRESSION OF TEST RESULTS

The following results shall be calculated for each measuring occasion and each specimen.

8.1 Dilation ξ_L (from Reference procedure)

$$\xi_L = \frac{l_i - l_0}{l_0} \times 100 \quad [\%] \quad (1)$$

where

l_i = the length reading after i cycles of freezing-and-thawing (mm)

l_0 = the initial length reading (mm)

L_0 = the initial length of the specimen, $L_0 = 150 + l_0$ (mm).

8.2 Relative UPTT γ (from Alternative procedure A)

$$\gamma = \frac{t_i}{t_0} \quad (2)$$

where

t_i = the transmission time measured after i cycles of freezing-and-thawing (μ s)

t_0 = the initial transmission time (μ s).

8.3 Relative dynamic modulus RDM (from Alternative procedure B)

Assuming that $m_i/m_0 \approx 1$,

$$RDM = \left(\frac{f_i}{f_0} \right)^2 \quad (3)$$

where

f_i = the fundamental frequency measured after i cycles of freezing-and-thawing (kHz)

f_0 = the initial fundamental frequency (kHz).

The individual values of each specimen and the mean values from four specimens are used for evaluating the resistance of concrete to internal frost damage.

9. PRECISION

9.1 Dilation

The precision data for dilation are given in Table 2. These data apply for laboratory concrete series which are measured according to section 5.

Table 2 – Precision data of measurement of internal damage - Reference method				
Test parameter	Internal deterioration			
	Not deteriorated	Possibly deteriorated	Deteriorated	Severely deteriorated
Dilation ξ_L [%]	< 0.03	0.03 ~ 0.1	0.1 ~ 0.2	> 0.2
standard deviations				
Precision of repeatability s_r (includes scatter due to operator, material and ultrasonic test) [%]	0.022	0.029	0.045	0.055
Precision of reproducibility s_R [%]	0.027	0.037	0.062	0.076
Resistance class	Good	Intermediate	Poor	Very poor

(* If the scaling resistance is simultaneously tested the scaled material should be collected according to the procedure described in prEN – “Slab Test - Freeze/Thaw Resistance of Concrete - Scaling deterioration” (under development by CEN/TC 51 N457).

The measurement precision can be expressed as (ξ_L in percent values):

$$s_r = 0.195 \xi_L + 0.016 [\%] \quad (\xi_L \text{ 0 to 0.3 with } R^2 = 0.79) \quad (4)$$

$$s_R = 0.291 \xi_L + 0.018 [\%] \quad (\xi_L \text{ 0 to 0.3 with } R^2 = 0.93) \quad (5)$$

where s_r and s_R denote the standard deviation of repeatability and reproducibility and ξ_L is the dilation calculated according to Equation (1).

REMARK: The above equations are based on the results of the inter-comparison test of RILEM TC IDC with 6 institutes testing 3 different kinds of concrete series.

9.2 Relative UPTT

The precision data for UPTT are given in Table 3. These data apply for laboratory concrete series which are measured according to section 6.1.

Table 2 – Precision data of measurement of internal damage - Reference method				
Test parameter	Internal deterioration			
	Not deteriorated	Possibly deteriorated	Deteriorated	Severely deteriorated
Relative UPTT γ	< 100%	100 % ~ 110%	110 % ~ 120%	> 120%
	standard deviations			
Precision of repeatability s_r (includes scatter due to operator, material and ultrasonic test)	2.0%	3.3%	5.9%	7.3%
Precision of reproducibility s_R	2.1%	3.5%	6.3%	7.6%
Resistance class	Good	Intermediate	Poor	Very poor

The measurement precision can be expressed as:

$$s_r = 0.264 \gamma - 0.244 \quad (\gamma \text{ 1 to 1.3 with } R^2 = 0.86) \quad (6)$$

$$s_R = 0.277 \gamma - 0.256 \quad (\gamma \text{ 1 to 1.3 with } R^2 = 0.86) \quad (7)$$

where s_r and s_R denote the standard deviation of repeatability and reproducibility and γ is the relative UPTT calculated according to Equation (2).

REMARK: The above equations are based on the results of the inter-comparison test of RILEM TC IDC with 5 institutes testing 3 different kinds of concrete series.

Relative dynamic modulus

No reliable statistic result is presently available for this measurement.

10. REPORT

The test report shall contain at least the following information:

- a) A reference to this standard,
- b) Origin and marking of the specimen,
- c) Composition of the concrete,
- d) Composition of the freezing medium,
- e) Test results, rounded to the nearest 0.01,
- f) Visual assessment (cracks, scaling from aggregate particles, leakage of the freezing medium, etc.),
- g) Any deviation from the procedure described in this method.