



RILEM TC 119-TCE: AVOIDANCE OF THERMAL CRACKING IN CONCRETE AT EARLY AGES

Recommendations

The texts presented hereunder are drafts for general consideration. Comments should be sent to the TC Chairman, Professor R. Springenschmid, Institute for Construction Materials, Technical University of Munich, Baumbachstr. 7, D-81245 Munich, Germany, before 1st February 1998.

TC Membership: **Chairman:** R. Springenschmid, Germany; **Secretary:** M. Plannerer, Germany; **Editorial Secretary:** J.-L. Bostvironnois, Germany; **Members:** P. Acker, France; S. Bernander, Sweden; R. Breitenbücher, Germany; K. van Breugel, Netherland; M.J. Coole, Great Britain; M. Emborg, Sweden; H. Grube, Germany; H. Hamfler, Germany; M.J. Hammons, USA; H. Huber, Austria; C. Jaegermann, Israel; F. Jung, Austria; M. Mangold, Germany; P. Morabito, Italy; P.K. Mukherjee, Canada; F.S. Rostásy, Germany; A.R. Solovjantchik, Russia; T. Tanabe, Japan; P.J. Wainwright, Great Britain.

TCE1: Adiabatic and semi-adiabatic calorimetry to determine the temperature increase in concrete due to hydration heat of the cement

Foreword

This Technical Recommendation was drafted by P. Morabito, Italy, and revised after discussion in Technical Committee 119-TCE and its subcommittee on hydration heat.

1. SCOPE

One of the most important factors associated with thermal cracking in concrete is the evolution and distribution of the temperature increase throughout the section at any time after casting. The temperature increase is a direct result of the heat evolved from the hydration of the cement.

The majority of standard tests currently in use for measuring the heat of hydration of cement are carried out at a constant temperature. The prediction of the temperature increase of concrete from these results can be difficult, because these isothermal tests do not take account of the change in reactivity of the cement with changing temperature and therefore do not reflect the conditions in the real structure where the temperature changes continually.

The alternative approach is to use adiabatic or semi-adiabatic calorimeters in which are tested concrete specimens of the same mix as will be used on site.

Such methods aim at determining the evolution of the adiabatic temperature increase under conditions which are very similar to those at the centre of a large pour.

The present recommendation gives details of the apparatus and describes the procedure to determine the evolution of the adiabatic temperature in a specific concrete.

2. DEFINITIONS

Adiabatic calorimeter: a calorimeter is considered to be adiabatic if the temperature loss of the sample is not greater than 0.02 K/h.

Semi-adiabatic calorimeter: a calorimeter where the maximum heat losses are less than 100 J/(h·K).

Coefficient of temperature loss a [K/h]: Decrease in temperature of the sample for unit time.

Time constant τ [h]: Parameter of the exponential cooling curve.

Coefficient of heat loss α [J/(h·K)]: Quantity of heat lost from the sample for unit of time and for a unit temperature difference between sample and environment.

Temperature increase of the concrete sample θ_s [K]: Temperature increase of the sample measured during hydration in a calorimeter.

Adiabatic temperature increase θ_{ad} [K]: True adiabatic temperature increase of concrete.

Temperature increase θ_{HH} [K]: Intrinsic temperature increase calculated from tests in a semi-adiabatic calorimeter.

Temperature T_s [°C]: Temperature of the sample.

Boundary temperature T_a [°C]: Temperature of the sample surroundings.

Apparent heat capacity of calorimeter C_{cal} [J/K]: Heat capacity exhibited from the calorimeter.

Heat capacity of the sample C_s [J/K]: Specific heat of concrete multiplied by the mass of the sample.

Total heat capacity C_T [J/h]: Amount of the total heat capacity exhibited from the calorimeter and the sample ($C_T = C_{cal} + C_s$).

3. PRINCIPLE OF MEASUREMENT

The measurement method consists of introducing into the calorimeter a sample of fresh concrete just after the mixing and measuring the temperature of the specimen. Adiabatic calorimeters rely on the principle that, at any time during the test, the temperature of the sample surroundings must be equal to the temperature of the concrete. This condition requires that additional heat be supplied from outside.

Semi-adiabatic calorimeters rely only on some form of insulation around the sample to slow down the rate of heat loss.

The hydration heat of the tested concrete will be divided into three parts:

- heating of the specimen
- heating of the calorimeter
- heat loss.

The heating of the calorimeter must be regarded as an apparent heat capacity of the apparatus, including the sample container, and has to be determined for each type of calorimeter.

The heat losses play a different role for the two kinds of equipment. In adiabatic calorimeters, they are usually small and almost constant throughout the duration of the test and give rise to a residual correction to determine the adiabatic temperature from the measured one. In semi-adiabatic calorimeters, they are not constant throughout the run time of the test, as they increase with the increasing temperature of the sample and provide the major contribution to the calculation of the adiabatic temperature increase of the specimen.

From the point of view of the reliability in determining the adiabatic temperature increase, the main difference between the two measurement methods is that the temperature of the sample in an adiabatic calorimeter is at any time very close to the adiabatic temperature, so the influence of the change in reactivity of the cement with the temperature is directly taken into account. In a semi-adiabatic calorimeter, the heat losses give rise to a temperature of the sample lower than the adiabatic temperature and a maturity function must therefore be assumed in order to take account of the change in reactivity of the cement. This can give rise to some approximation in determining the adiabatic temperature increase of the tested concrete.

4. APPARATUS

4.1 Adiabatic calorimeter

Fig. 1 shows a schematic view of an adiabatic calorimeter.

The sample is cast in a cylindrical container fitted with a cover. The container should be tight against water vapour, which will be checked by weighing the sample before and after the test. The reduction of mass of the sample should be less than 0.1%.

The dimensions of the container should take into account the thermal capacity effects of a maximum aggregate size of around 32 mm. To incorporate this aggregate size, the volume of the sample must be about 4,000 cm³ and the smallest dimension of the sample must be at least three times the maximum size of the aggregate. The ratio between the apparent heat capacity of the calorimeter to the heat capacity of the sample must be limited to 0.1; such a condition is achieved by performing tests on large volume samples using thin containers. If the condition $C_{cal}/C_s \leq 0.1$ is not satisfied, a thermal compensation should be adopted (see Appendix 1), otherwise the test method should be considered as semi-adiabatic.

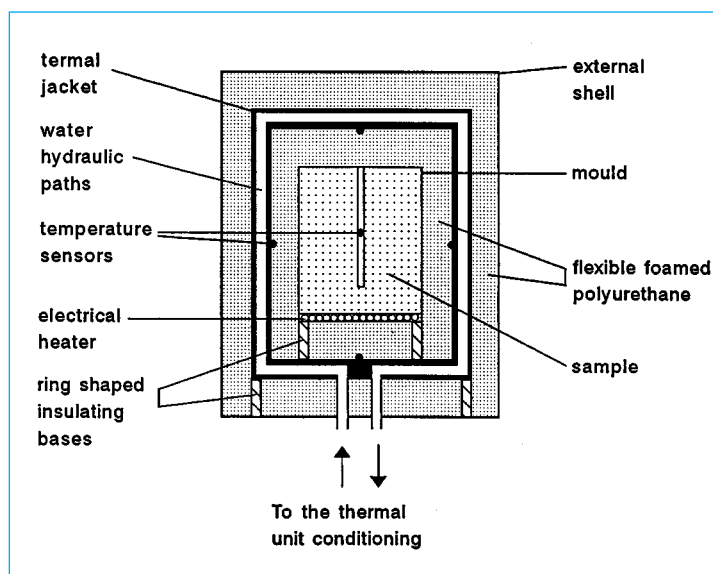

Fig. 1 – Sketch of a typical adiabatic calorimeter.

The casing of the sample container should have a sufficiently wide base to ensure good stability against falling over. It is advisable to provide the base with an electric heater to supply external heat for purposes of calibration or thermal compensation of the calorimeter.

The temperature of the specimen is measured with a PT100 resistance thermometer or a thermistor inside a tube placed along the axis of the sample. To ensure good thermal contact the tube should be filled with oil.

The temperature of the calorimeter is controlled by a thermal jacket which should be capable of producing an isothermal surface around the sample whose temperature must follow the sample temperature. The thermal jacket

will have the same cylindrical shape as the sample and be made of steel or aluminium (the latter is to be preferred because of its lower unit weight). Inside the jacket, water is circulated, the temperature of which is controlled by an auxiliary thermal conditioning unit whose working temperature should range from 5°C up to 80°C in order to be able to simulate the hydration of concrete with the same initial temperature as on site. Some form of insulation, such as a flexible foamed polyurethane sheet 3 cm thick, should be provided between the sample and the thermal jacket; this improves the equalisation of the temperature around the sample, will minimise the accidental risk of supplying heat directly to the sample and will make the degree of sensitivity of the temperature controller less critical. A second layer of thermal insulation inserted between the jacket and the external shell will minimise any effects that the environmental temperature might have on the test. The temperature of the jacket shall be regulated by a controller whose sensitivity influences the amount by which the temperature of the jacket cycles around the set point, and consequently will affect the amount of heat that is lost or gained. Since the temperature of the jacket must never be allowed to exceed the temperature of the sample under test, the temperature of the jacket is set slightly lower than the sample temperature and the difference between the two is carefully controlled. A small amount of heat loss is thus unavoidable.

The temperature difference must be such that the temperature loss of the sample is less than 0.02 K/h and to achieve this, temperature sensors having a sensitivity of ± 0.01 K should be used (PT100 or thermistors).

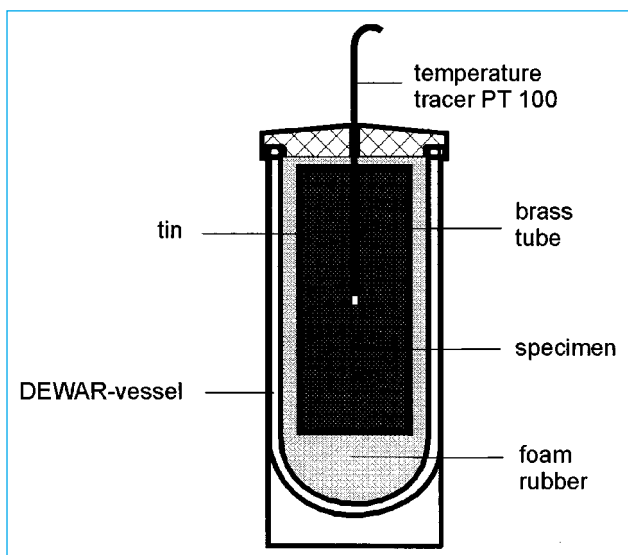

Fig. 2 – Example of a semi-adiabatic calorimeter using a commercial thermos vessel.

4.2 Semi-adiabatic calorimeter

A semi-adiabatic calorimeter is essentially made up of an insulating vessel filled with foam rubber and of an external shell to protect the thermos vessel from damage (Fig. 2).

The dimensions of the sample and the method of measuring the temperature are the same as for an adiabatic calorimeter. The ambient temperature where the vessel is placed is fixed at $20^{\circ}\text{C} \pm 1^{\circ}\text{C}$. The coefficient of total heat loss shall not exceed 100 J/h/K. The vessel should be placed away from any heat sources and strong air currents. The speed of the ventilation air around the calorimeter should be less than 0.5 m/s. When several tests are being carried out simultaneously, the minimum distance between vessels should be over 10 cm.

5. CALIBRATION

The calculation of the adiabatic temperature increase from the measured curves is given in Appendix 2 and requires the knowledge of C_s , α , t and C_{cal} ; the last three coefficients depend on the characteristics of the calorimeter and therefore must be determined through a calibration.

The calibration sample shall be of distilled water (specific heat equal to 4,186 J/kg/K in the range from 0°C to 100°C) which is to be subjected to the following steps:

- heating of the sample
- spontaneous cooling of the sample.

5.1 Adiabatic calorimeter

First, the total thermal capacity C_T of the calorimeter containing the calibration sample is determined; then that of the calorimeter alone is deduced.

The sample container is filled with distilled water and left for a period of about 10 hours to stabilise the system. After this time, the sample is heated at constant power P [W] under adiabatic conditions for a time \bar{t} of about 20 h. The level of power should be such as to give a rise in temperature θ_s equal to 30-40°C, the rate of temperature increase should be maintained constant ($\alpha = \text{const.}$). After this time, the power is switched off and the sample is kept under adiabatic conditions for 10 h to stabilise the system.

The power supplied is expressed as:

$$P \cdot \bar{t} = C_T (\vartheta_s + a \cdot \bar{t}) = C_T \left[\vartheta_s + \frac{(T_s - T_a)}{\tau} \cdot \bar{t} \right]$$

In order to determine τ , the temperature of the thermal jacket is lowered to a temperature T_{j0} of about 10-20°C; the sample will then cool spontaneously according to the following expression:

$$\frac{d[T_{j0} - T_s(t)]}{T_{j0} - T_s(t)} = \frac{dt}{\tau}$$

whence:

$$\tau = \frac{t}{\ln \frac{T_{j0} - T_{s0}}{T_{j0} - T_{st}}}$$

where: t = elapsed time

T_{so} = temperature of the sample at starting time of cooling

T_{st} = temperature of the sample at point in time t
 \ln = natural logarithm.

If the temperature controller does not allow a steep descent of the temperature of the jacket to be achieved, an alternative way is to remove the sample from the calorimeter and keep it at about 50°C in an oven, reduce the temperature of the jacket to T_{jo} and, when this temperature is reached, replace the sample in the calorimeter. The cooling period should run for about 30 h.

The apparent heat capacity is given by:

$$C_{cal} = C_T - 4186 \cdot m_w \quad [J / K]$$

m_w being the mass in kg of the water sample.

5.2 Semi-adiabatic calorimeter

The coefficient α is determined by measuring in steady state conditions the equilibrium temperature T_s for different levels of constant electrical power P provided to the calibration sample. When stable conditions are achieved, the heat supplied is completely dissipated into the environment. The equation for the losses is expressed as:

$$P = \alpha \cdot \vartheta_s$$

α should be independent of the temperature; however, this should be checked at 5 points in the temperature range observed during the hydration tests (for example, for temperature increases of 10, 17, 24, 31, 38 K) and a mean constant value will be assumed.

The measurement of the thermal capacity C_{cal} is carried out by the method of spontaneous cooling of the water sample. For this purpose, the sample is disconnected from the electrical power supply after reaching the steady state condition for the last point of calibration to determine α . During cooling, the heat exchange equation is expressed as:

$$-C_T \cdot d\vartheta = \alpha \cdot \vartheta \cdot dt$$

whence:

$$C_T = \frac{\alpha \cdot t}{\ln \frac{\vartheta_o}{\vartheta_t}}$$

with: t = elapsed time since disconnecting the power supply

ϑ_o = temperature increase at starting time

ϑ_t = temperature increase at point in time t .

6. EVALUATION OF THE HEAT CAPACITY OF CONCRETE

6.1 Experimental evaluation

After the heat capacity of the calorimeter is known, the heat capacity of the concrete specimen can be deter-

mined according to the same procedures used to determine C_T , with the difference that the calibration sample is replaced by a concrete sample which has been allowed to completely hydrate; so:

$$C_s = C_T - C_{cal}$$

6.2 Calculated evaluation

The heat capacity of concrete is temperature-dependent and also depends on the hydration rate during the adiabatic or semi-adiabatic tests. Consequently, the experimental values are not better than the calculated values obtained from a knowledge of the composition of concrete and the specific heat of the components.

Calculation of the heat capacity of the sample is performed according to the following formula:

$$C_s = m_s \sum g_i \cdot c_i$$

with: m_s = mass of the concrete sample in kg

g_i = content by mass of mix components

c_i = specific heat of mix components:

aggregate: $c_a = 0.7-0.9$ kJ/kg/K

cement: $c_{ce} = 0.84$ kJ/kg/K

water: $c_w = 4.186$ kJ/kg/K

7. TESTING PROCEDURE

The testing procedure is performed through the following two steps:

- hydration of the concrete sample;
- calculation of τ .

The volume of the batch should be more than the volume of the sample to be tested and all the constituents will be kept at the constant starting temperature for one day prior to mixing. The temperature of the fresh concrete should differ not more than ± 2 K from the temperature of the calorimeter. The concrete is placed inside the container, vibrated and weighed. The measurement of the temperature increase starts no later than 10-15 minutes from the start of the mixing. The measuring period is usually over seven days and calculation of τ is carried out for each concrete sample tested by spontaneous cooling at the end of the hydration period. Finally, data reduction is performed according to the procedure given in Appendix 2.

7.1 Adiabatic test

The difference $T_s - T_j$ is set to a value such that the coefficient of the temperature loss is less than 0.02 K/h. The temperature of the thermal jacket is regulated continuously or at a rate of no more than every 30 s. Over the whole period of hydration, data recording of T_s and T_j is performed; the experimental evaluation of τ is carried out as described in 5.1.

7.2 Semi-adiabatic test

The temperature of the thermos vessel is adjusted to the ambient temperature. The temperature of the fresh concrete should be equal to the ambient temperature within ± 2 °C. After the measuring period, the specimen is removed from the vessel and stored to let hydration cease. Then the specimen in the closed container is heated up in an oven to about 50°C and inserted in the thermos vessel. By means of the measured temperature loss the time constant τ is determined.

Because of the semi-adiabatic conditions, data reduction leads to a temperature increase θ_{HH} which is a lower estimate of the adiabatic temperature increase; an example of stepwise calculation is given in Appendix 3.

The estimate can be improved by considering the influence of the temperature on the hydration by means of a maturity function. In general, the temperature factor k_T of Arrhenius gives a good approximation for the temperature dependence of the hydration of cement:

$$k_T = e^{\frac{E_A}{R} \left(\frac{1}{293} - \frac{1}{273+T} \right)}$$

with: T temperature in °C

E_A activation energy in J/mol

R universal gas constant = 8.314 J/(mol·K)

$$\frac{E_A}{R} = \begin{cases} 4000 & \text{for } T \geq 20^\circ\text{C} \\ 4000 + 175(20 - T) & \text{for } T < 20^\circ\text{C} \end{cases} \text{ for Portland cements}$$

$$\frac{E_A}{R} = 6000 \text{ for slag cements}$$

The assumed maturity function is:

$$M = \int_0^t k_T dt$$

The correction is done stepwise according to the following equations:

$$\vartheta_{ad}(t) = \vartheta_{HH}(M)$$

$$\text{with time } t = \int_0^M \frac{1}{k_T} dM$$

and $T_s = T_o + \vartheta_{HH}(M) = T_o + \vartheta_{ad}(t)$, T_o being the initial temperature of the specimen. An example for the calculation scheme is given in Appendix 4.

8. TEST RESULTS

The test report will document the characteristic parameters of the apparatus and the relevant data of the test.

For the apparatus the following data will be given:

- working principle (adiabatic or semi-adiabatic)
- volume of the sample
- apparent heat capacity of the calorimeter
- coefficient of heat losses α
- date of the last calibration
- ambient temperature T_a for semi-adiabatic calorimeter
- the assigned value of $T_s - T_j$ for adiabatic calorimeter.

For each test the following data will be documented:

- concrete composition
- initial temperature of the mix
- initial weight of the sample
- duration of the measuring period
- time, temperature of the sample, ambient temperature (for semi-adiabatic test), jacket temperature (for adiabatic test) at steps not greater than 0.5 h: these data can be tabulated or plotted
- final weight of the sample
- heat capacity of the sample (specify if calculated or measured)
- time constant τ
- total heat quantity liberated by the unit weight of concrete.

9. SOME REMARKS ON THE CHOICE OF ADIABATIC OR SEMI-ADIABATIC TEST

Although both types of testing method make it possible to determine the adiabatic temperature increase of a given concrete sample, semi-adiabatic tests are generally easier to conduct. On the other hand, hydration curves from adiabatic calorimeters are determined quite accurately.

The choice of the test type will depend on the degree of accuracy with which the laboratory test should simulate the hydration in the real structure. For thermal analysis of mass concrete structures where the temperature increase is expected to be almost adiabatic, or when the true adiabatic temperature increase and heat of hydration are required, the use of an adiabatic calorimeter is recommended.

In structures of smaller size where heat losses are expected, greater precision in the prediction of the temperature increase can only be achieved from a knowledge or estimate of the expected temperature loss. This of course is an extremely difficult figure to calculate, but assuming it to be possible, then either the calorimeter could be designed to reproduce this loss or adjustments could be made to the measured curve. In both cases, a semi-adiabatic test may be more favourable: the semi-adiabatic hydration curve could be in relatively close agreement already with the hydration process as it actually develops in the structure; inaccuracy of any adjustment that allows for minor deviations of the actual temperature in the structure from the semi-adiabatic curve can be kept to a minimum.

APPENDIX 1: THERMAL COMPENSATION FOR THE APPARENT HEAT CAPACITY OF THE CALORIMETER

The thermal compensation technique consists of supplying, by the electrical resistor, an external heat source equal to that accumulated from the apparent heat capacity C_{cal} while the hydration test is in progress.

For this, the testing time is divided into intervals Δt_i equal to 0.5 h. Starting from the second interval from

the beginning of the hydration, the heat to be supplied in each interval Δt_i is calculated according to the following expression:

$$E_i = [T_s(t_{i-1}) - T_s(t_{i-2})] \cdot C_{cal}$$

The power to be supplied is given by:

$$P_i = \frac{E_i}{\Delta t_i}$$

The corresponding temperature increase at the end of the test is corrected for the apparent heat capacity of the calorimeter, so data reduction will take into account the heat losses alone.

A check of the reliability of the thermal compensation technique should be made at the end of the test through the following verification:

$$\frac{C_{cal}}{C_T} = \frac{E_T}{\vartheta_s \cdot C_s + E_T}$$

being $E_T = \sum E_i$ the total heat supplied during the test.

APPENDIX 2: CALCULATION OF THE ADIABATIC TEMPERATURE

The adiabatic temperature at point in time t is expressed as:

$$\vartheta_{ad}(t) = \left(1 + \frac{C_{cal}}{C_s}\right) \cdot \left[\vartheta_s(t) + \int_0^t a(t) \cdot dt\right] \quad (1)$$

The following relationships exist between the coefficients of temperature loss a , heat loss α and the time constant τ of the calorimeter with the sample to be tested inside it:

$$a = \frac{\alpha(T_s - T_a)}{C_T} \quad (2)$$

$$\tau = \frac{C_T}{\alpha} \quad (3)$$

$$a = \frac{T_s - T_a}{\tau} \quad (4)$$

Equation (1) can be written in terms of heat of hydration Q given off by a unit weight of concrete:

$$Q(t) = \frac{C_T \cdot \vartheta_s(t)}{m_s} + \frac{C_T}{m_s} \cdot \int_0^t a(t) dt \quad (5)$$

$$= \frac{C_T}{m_s} \vartheta_s(t) + \frac{1}{m_s} \int_0^t \alpha [T_s(t) - T_a(t)] dt$$

where m_s is the mass in kg of the tested sample.

For adiabatic calorimeters, T_a is equal to the temperature of the thermal jacket T_j and the difference $T_s(t) - T_a(t)$ should be constant at any point during the test.

In semi-adiabatic tests, T_a is the temperature of the

environment in which the apparatus is placed; T_a shall be kept constant (20°C) so the difference $T_s(t) - T_a(t)$ is equal to $\theta_s(t)$.

APPENDIX 3: EXAMPLE OF A STEPWISE CALCULATION TO DETERMINE THE INTRINSIC TEMPERATURE INCREASE FROM A SEMI-ADIABATIC TEST

The temperature θ_{HH} of the concrete specimen according to the defined semi-adiabatic conditions is given by:

$$\vartheta_{HH} = \left(1 + \frac{C_{cal}}{C_s}\right) \cdot \left[\vartheta_s + \sum a \cdot \Delta t\right]$$

Table 1 shows an example for the calculation scheme.

$$C_s = 4040 \text{ J/K} \quad C_{cal} = 800 \text{ J/K} \quad \tau = 24.8 \text{ h}$$

t	Δt	T_s	θ_s	T_a	$T_s - T_a$	$a \Delta t$	$\Sigma a \Delta t$	$\theta_s + \Sigma a \Delta t$	θ_{HH}
h	h	°C	K	°C	K	K	K	K	K
0		19.9	0.0	19.9			0.00	0.00	0.0
1	1.0	20.5	0.6	20.0	0.3	0.01	0.01	0.61	0.7
	1.0	20.7	0.8	20.0	0.6	0.02	0.03	0.83	1.0
2	1.0	21.0	1.1	20.0	0.9	0.03	0.06	1.16	1.4
	1.0	21.5	1.6	20.0	1.3	0.05	0.11	1.71	2.1
3	1.0	22.4	2.5	19.9	2.0	0.08	0.19	2.69	3.2
	
15		40.1	20.2	20.1			5.14	25.34	30.4
16	1.0	40.4	20.5	20.1	20.2	0.81	5.95	26.45	31.7
	1.0	40.5	20.6	20.1	20.4	0.82	6.77	27.37	32.8
17	1.0	40.5	20.6	20.1	20.4	0.82	7.59	28.19	33.8
	1.0	40.4	20.5	20.1	20.4	0.82	8.41	28.91	34.7
18	1.0	40.2	20.3	20.0	20.3	0.82	9.23	29.53	35.4
	
80		22.9	3.0	20.0			33.08	36.08	43.3
84	4.0	22.6	2.7	20.0	2.8	0.44	33.52	36.22	43.5
	4.0	22.3	2.4	19.9	2.5	0.40	33.92	36.32	43.6
88	4.0	22.0	2.1	20.0	2.2	0.35	34.27	36.37	43.7
	4.0	21.9	2.0	20.1	1.9	0.31	34.58	36.58	43.9
92	4.0	21.7	1.8	19.9	1.8	0.29	34.87	36.67	44.0
	4.0								

APPENDIX 4: EXAMPLE OF A STEPWISE CALCULATION TO ESTIMATE THE ADIABATIC TEMPERATURE BY MEANS OF THE MATURITY FUNCTION

semi - adiabatic						$\theta_{HH} = \theta_{ad}$	adiabatic			
t	Δt	T_S	K_T	ΔM	M		$T_O + \theta_{ad}$	K_T	Δt	t
h	h	°C	-	h	h	K	°C	-	h	h
0		19.9			0.0	0.0	20.0			0.0
1	1.0	20.2	1.009	1.01	1.0	0.7	20.7	20.4	1.017	0.99
2	1.0	20.5	1.028	1.03	2.0	1.0	21.0	20.9	1.041	0.99
3	1.0	20.7	1.040	1.04	3.1	1.4	21.4	21.2	1.057	0.98
4	1.0	21.0	1.060	1.06	4.1	2.1	22.1	21.7	1.084	0.98
5	1.0	21.5	1.094	1.09	5.2	3.2	23.2	22.7	1.130	0.97
...	
15		40.1			23.0	30.4	50.4			13.1
16	1.0	40.3	2.417	2.42	25.4	31.7	51.7	51.1	3.700	0.65
17	1.0	40.4	2.437	2.44	27.9	32.8	52.8	52.3	3.876	0.63
18	1.0	40.5	2.422	2.44	30.3	33.8	53.8	53.3	4.031	0.61
19	1.0	40.5	2.437	2.44	32.7	34.7	54.7	54.2	4.173	0.58
20	1.0	40.4	2.422	2.42	35.2	35.4	55.4	55.1	4.300	0.56
...	
80		22.9			130.2	43.3	63.3			34.1
84	4.0	22.6	1.135	4.54	134.8	43.5	63.5	63.4	5.815	0.78
88	4.0	22.3	1.120	4.48	139.3	43.6	63.6	63.5	5.846	0.77
92	4.0	22.0	1.105	4.42	143.7	43.7	63.7	63.6	5.865	0.75
96	4.0	22.0	1.094	4.38	148.0	43.9	63.9	63.8	5.898	0.74
100	4.0	21.9	1.087	4.35	152.4	44.0	64.0	64.0	5.935	0.73

TCE2: Method for in situ measurement of thermal stress in concrete using the stress meter

Foreword

Thermal and other restraint stresses in young concrete cannot be determined by the use of traditional methods based on a measurement of deformations. The stress meter enables a good approximation of thermal stresses in concrete. The design concept of the stress meter was developed by the Kajima Technical Research Institute. The Technical Recommendation was drafted by T. Tanabe, Japan.

1. SCOPE

This recommendation describes a method for *in situ* measurement of thermal stresses during the hardening of concrete using a stress meter which was especially developed for this purpose and which is embedded in con-

crete. The recommendation briefly describes the principle of the measurement, including the details of the stress meter used and its installation.

2. PRINCIPLE OF MEASUREMENT

The measurement of thermal stresses in concrete at early ages cannot be easily carried out using the conventional means of only monitoring the strains, mainly because the other properties such as Young's modulus, etc. are not accurately known.

The principle of measurement described in this recommendation using the embedded stress meter is shown schematically in Fig. 1.

The method uses essentially a load cell in series with concrete cast in the stress meter (hereinafter referred to as a

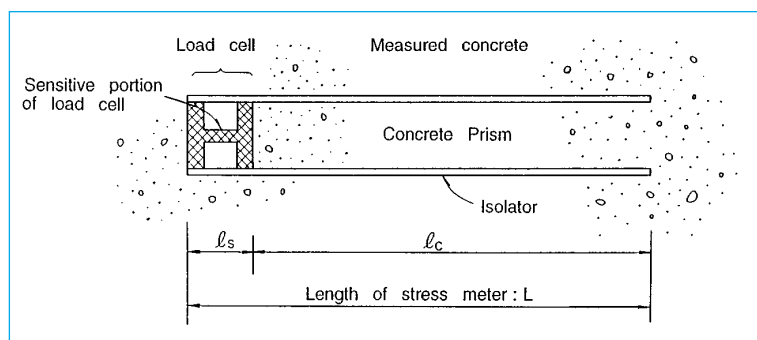

Fig. 1 - Basic structure of the stress meter.

concrete “prism”) at the time of casting the surrounding mass concrete. There is no mechanical bond between the prism and the mass concrete along the four walls.

The stress in the concrete prism is obtained by dividing the force (as measured by the load cell) by the cross-sectional area of the prism. Also, since the length of the load cell (l_s) is much smaller compared to the length of the concrete prism (l_c), it can be assumed that the latter is approximately equal to the gauge length ($L = l_s + l_c$) of the surrounding concrete. Furthermore, the method ensures that the properties of the prism, such as the Young’s modulus, creep, etc. and those of the surrounding concrete are similar, by allowing a free exchange of water across the walls.

Essentially, the thermal stress in the surrounding concrete is related to the stress in the prism concrete (concrete within the stress meter) as follows :

$$\sigma_c = \frac{1}{(K_g/K_c)} \cdot \sigma_g \quad (1)$$

where:

- σ_c stress in the surrounding concrete
- σ_g stress in the concrete prism
- K_g rigidity of the overall system comprising the load cell and the prism
- K_c rigidity of the surrounding concrete.

Thus, in order to ensure accurate measurement of σ_c , the rigidities of the stress meter system (load cell and prism) and the surrounding concrete must have, in as far as possible, the same value.

A more detailed discussion on the effect of the length and stiffness of the load cell, etc. on the accuracy of the measured thermal stresses is given in the Appendix.

3. STRESS METER*

Fig. 2 shows schematically the stress meter used. The device consists of a load cell which is fixed at one end of an open box made of wire mesh. The prism and the outside concrete are “monolithic” through the anchor that is provided at one end. A similar anchor is provided at the load cell. The lid of the box is also made of wire mesh and is used to cover the concrete prism after casting. The thermal stresses generated in the concrete due to restraint, etc.

are directly obtained using the data from the load cell.

The walls of the stress meter, including the lid, are lined with blotting paper, pour sheet and felt. This arrangement allows a free exchange of water between the concrete within and outside the device, ensures that there is no mechanical bond between the concrete inside and outside the meter along the four walls, and provides continuity between the concrete prism and the surrounding concrete through the anchors.

Thus, the properties of concrete within the device, e.g. the Young’s modulus, creep coefficient, etc., are almost the same as those of the bulk concrete, and any thermal stresses can be accurately measured.

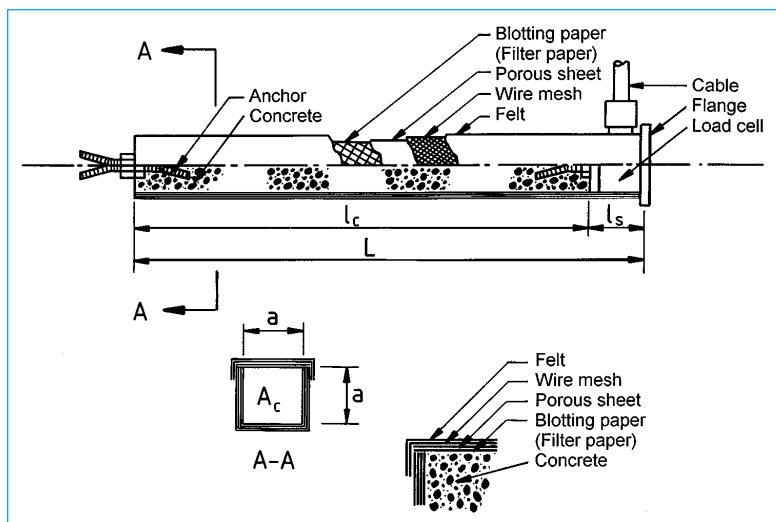

Fig. 2 - Schematic drawing of the stress meter.

Size of the typical stress meter
(Exemplary valid for one specific type of stress meter)

Length of the stress meter (L)	50 cm
Length of the load cell (l_s)	5 cm
Length of the concrete box (l_c)	45 cm
Mean value of sectional area of the load cell (A_g)	15.3 cm ²
Sectional area of the concrete box (A_c)	25 cm ²

4. IN SITU MEASUREMENT

4.1 Parameters to be recorded

In addition to the stresses (actually strains) as measured by the embedded stress meter, the following measurements may also be carried out to facilitate better analysis of the data.

4.1.1 Variation of temperature within the concrete: This measurement should be carried out at a location close to the one where the stress is being monitored.

(*) Addresses of suppliers of the stress meter may be obtained from the Institute for Construction Materials, Technical University of Munich, Baumbachstr. 7, D-81245 Munich, Germany, Fax: +49 89 289-27064, E-Mail: Baustoffinstitut@lrz.tu-muenchen.de

4.1.2 Variation of strain within the concrete: This measurement should also be recorded at a location close to the one where the stress is being monitored.

4.1.3 Variation of the atmospheric temperature: This is an important parameter in determining the development of thermal stresses in concrete and should be recorded at 2 or 3 suitable locations in the neighbourhood of the structure.

4.2 Installation of stress meter

The stress meter can be installed within concrete in a horizontal, vertical or any other position, to measure the thermal stresses in that direction. The stress meter needs to be fixed rigidly in place for accurate measurement of the stress in the desired direction. The steps in the installation of the stress meter can be briefly outlined as given below.

(1) Make a suitable holder which can be used to support the stress meter. Reinforcing bars, or any other suitable material can be used for this purpose, provided the meter can be securely held in place during concreting and that the stand provides the minimum restraint to the movement of the concrete in the direction of measuring.

(2) Secure the holder within the formwork before the concrete is cast. During casting, when the level of concrete reaches the level at which it is desired to install the stress meter, remove a sample of the concrete and fill the stress meter with it. It must be established that the following conditions are satisfied:

- the width of the stress meter is more than twice the size of the maximum size of the aggregate,
- the blotting paper and the felt lining of the stress meter have been moistened thoroughly before pouring concrete into it,
- the concrete placed in the meter (prism) should be compacted using a tamping rod or by vibrating.

(3) Once the meter has been completely filled with concrete, cover it with the upper lid and tie it securely using binding wires.

(4) Wrap the assembly using cloth and moisten with water until the stress meter is completely enclosed by concrete. Secure it to the holder within the formwork.

(5) The vibration in the neighbourhood of the stress meter may be carried out using mechanical needle vibrators. Care should be taken not to disturb the stress meter from its position.

Note: The above method for the installation of the stress meter may be suitably modified depending upon the type of the structure in question or the location chosen for monitoring the thermal stresses.

4.3 Frequency of measurement

The interval and duration of measurement depend upon the aim of the measurement, the type of the structure, etc. The following may, however, be used as a general guideline in conducting the measurements:

Age after placing	Frequency of collecting data
Up to 1 day	Every hour
1-3 days	Every 6 hours
3-7 days	Every 24 hours
After 7 days	Every 48 hours

It is recommended that the measurements be continued till the temperature of the concrete reaches the ambient temperature.

It may, however, be noted that the stresses can be accurately measured only so far as no cracks are formed in concrete in the neighbourhood of the stress meter.

5. RESULTS

A typical example of the results obtained using the stress meter, in terms of the stress history in a 1.5 m thick concrete, is shown in Fig. 3. The variation of temperature recorded is also given in Fig. 4 for reference. The figures show the initial compressive stresses generated during the period when the internal temperature rises, and the subsequent transition to tensile stresses on account of the “cooling” of the concrete. A sudden change in the measured stress values indicates possible formation of cracks in the neighbourhood of the meter and may be taken to mean that subsequent the stress values recorded are not accurate.

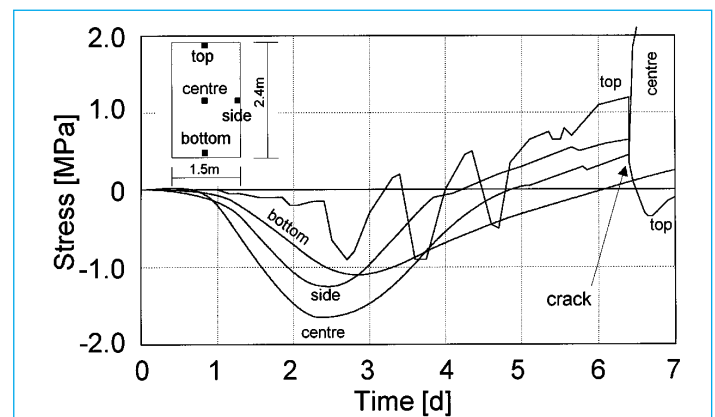

Fig. 3 – Development of measured stress in concrete structure.

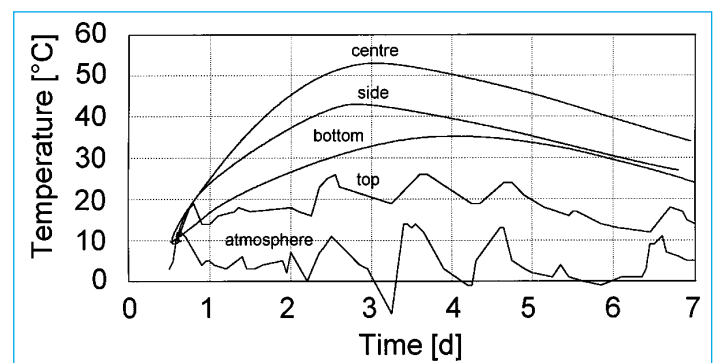

Fig. 4 – Development of temperature.

6. REPORT

A report giving the details of the measurement of thermal stress, carried out as outlined in this recommendation, must give the following details:

6.1 Basic information

- Details of the stress meter used, including the size and type of model used, the range of the load cell and the calibration constant
- Type of structure, including the size and details of the member
- Location and direction of the embedded stress meter
- Method of fixing the stress meter within the concrete
- Exact mix design (including the type of cement, cement content, maximum size of aggregate, etc.)
- Temperature of fresh concrete when placed
- Variation of the ambient temperature

6.2 Additional information

- Compressive strength development using laboratory specimens, including the details of measurement
- Tensile strength development using laboratory specimens, including the details of measurement
- Variation of temperature of concrete at the location of stress monitoring
- Variation of strain within concrete at the location stress monitoring

7. APPENDIX

7.1 Rigidity and error in measurement

From the schematic representation of the measurement of thermal stresses as given in Fig. 1, the rigidities of the stress meter and surrounding concrete depend upon their length and the modulus of elasticity of the load cell, etc. Their relationship can be expressed as follows:

$$\frac{K_g}{K_c} = \frac{I_s + I_c}{\frac{E_c \cdot A_c}{E_s \cdot A_s} \cdot I_s + I_c} \quad (2)$$

with:

- K_g rigidity of the load cell and the prism
- K_c rigidity of the surrounding concrete
- E_c, A_c Young's modulus and cross-sectional area of the concrete prism
- E_s, A_s Young's modulus and the cross-sectional area of the load cell
- l_c and l_s lengths of the concrete prism and load cell (see Fig. 1).

Based on equation (1) and using the Young's modulus of steel (210 GPa) for E_s , the variation of K_g/K_c with the Young's modulus of concrete for different values of l_s, l_c, A_s and A_c is given in Fig. A-1.

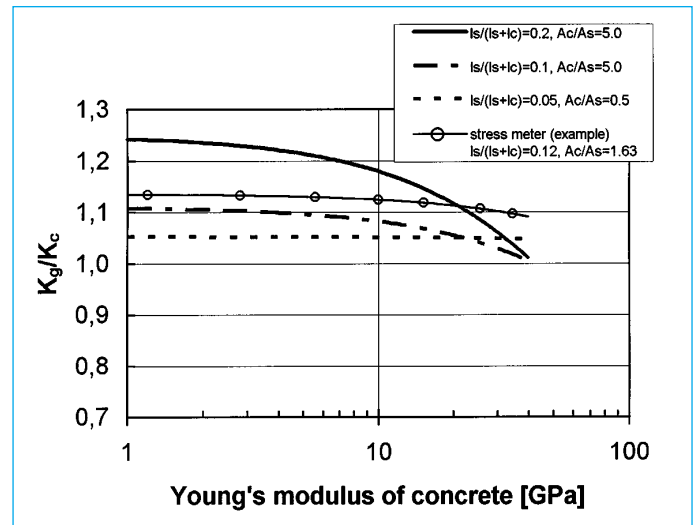

Fig. A.1 – Effect of the rigidity of the stress meter and of the Young's modulus of concrete on K_g/K_c .

From Fig. A.1, it can be seen that by having a large enough l_c compared to l_s , the ratio K_g/K_c approaches unity, a condition where the measurement ensures the best results.

7.2 Effect of creep and drying shrinkage

Because of the special feature of the stress meter, in which the prism is cast with the same concrete as the surrounding concrete, drying shrinkage and creep characteristics of the concrete in the stress meter are similar to the surrounding concrete and therefore the effect of these factors on the measured values of thermal stress is insignificant.

7.3 Effect of temperature

The coefficient of linear expansion of the stress meter (load-cell and the concrete prism) can be represented as follows :

$$\frac{\alpha_g}{\alpha_c} = \frac{\alpha_s \cdot I_s + I_c}{I_s + I_c} \quad (3)$$

with:

- α_g coefficient of linear expansion of the stress meter
- α_s coefficient of linear expansion of the load cell
- α_c coefficient of linear expansion of the surrounding concrete.

This equation also suggests that more accurate results can be obtained by increasing the length of the prism in relation to the length of the load cell. As an example, if α_s is taken to be $10 \cdot 10^{-6}/K$, l_s/l_c is assumed to be 0.1 and the range for α_c is taken as $9-13 \cdot 10^{-6}/K$, it is found that α_g/α_c is in the range 1.01-0.98. Thus it can be seen that the changes in temperature do not affect significantly the measured thermal stresses.

TCE3: Testing of the cracking tendency of concrete at early ages using the cracking frame test

Foreword

The cracking frame is a useful tool to assess thermal stresses in young concrete and to compare the cracking resistance of different concrete mixes in the laboratory. This Technical Recommendation was drafted by R. Breitenbücher, Germany.

1. SCOPE

To prevent thermal cracking in restrained concrete members at early ages, not only the temperature increase but also the stress development has to be considered. In addition, the temperature development, the development of the modulus of elasticity and relaxation are of importance for the stress development. To judge the cracking tendency, the development of tensile strength must also be considered. In an adiabatic or semi-adiabatic calorimeter, only the heat of hydration can be measured. In order to measure thermal stresses and determine the cracking tendency, tests in a restraining apparatus must be performed. The cracking frame has proved to be a useful tool for this purpose. In this equipment, a concrete beam hardens under semi-adiabatic conditions and under restraint. Such tests are carried out to judge the cracking tendency of various concretes.

2. DEFINITIONS

1st Zero stress temperature $T_{Z,1}$: Temperature at which, under restrained conditions, compressive stresses during the generation of hydration heat first occur due to the increasing modulus of elasticity. $T_{Z,1}$ describes the change from plastic to visco-elastic behaviour.

Maximum compressive stress $\sigma_{c,max}$: Maximum compressive stress under restrained conditions during the temperature increase. Due to the high relaxation of the compressive stresses, $\sigma_{c,max}$ will usually be reached before the maximum temperature has occurred.

Maximum temperature T_{max} : Maximum temperature of the concrete specimen during hardening under semi-adiabatic conditions.

2nd Zero stress temperature $T_{Z,2}$: Temperature at which, during the cooling phase, the compressive stresses have decreased completely to zero and tensile stresses start to develop. Due to the relatively high relaxation at very early ages and the high modulus of elasticity on cooling down, $T_{Z,2}$ normally is much higher than $T_{Z,1}$ and only a few degrees below T_{max} .

Cracking temperature T_c : Temperature at which the restrained specimen cracks, i.e. the tensile stresses have exceeded the tensile strength. The cracking temperature characterizes the cracking tendency of the concrete being tested: The tendency to thermal cracking at early ages is higher for higher cracking temperatures.

Tensile strength β_t : Tensile stress at time of cracking.

3. CRACKING FRAME*

3.1 Apparatus

The rigid cracking frame consists of a frame with two cross-heads and two massive steel bars (Fig. 1).

(*) Addresses of suppliers of the cracking frame may be obtained from the Institute for Construction Materials, Technical University of Munich, Baumbachstr. 7, D-81245 Munich, Germany, Fax: +49 89 289-27064, E-Mail: Baustoffinstitut@lrz.tu-muenchen.de

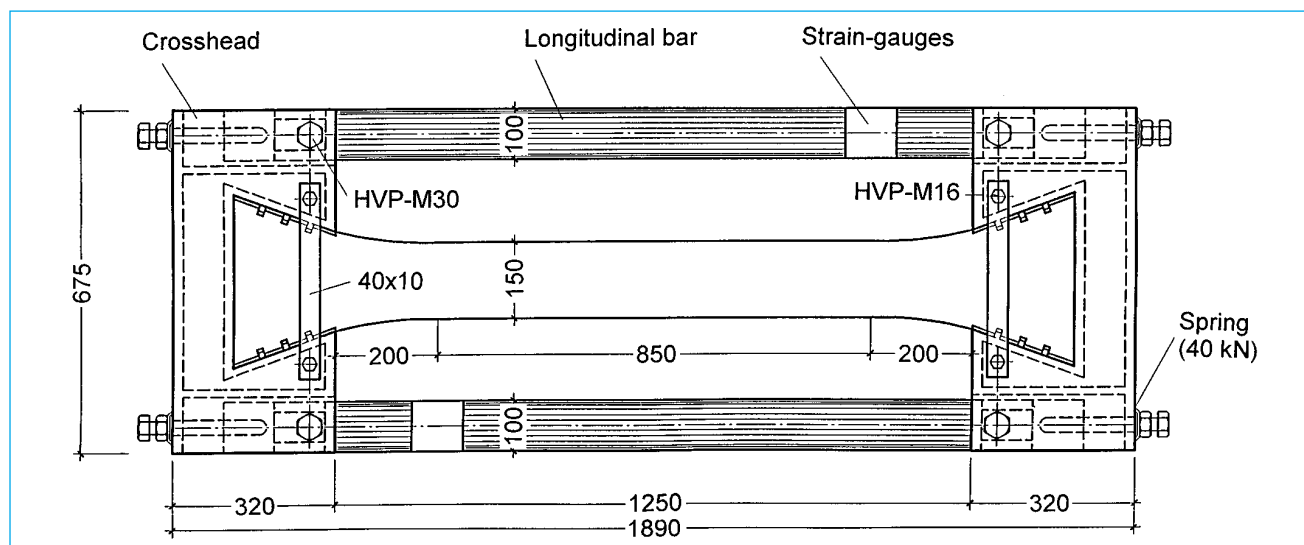

Fig. 1 – Cracking frame.

The longitudinal steel bars have a diameter of 100 mm. To guarantee minimal thermal deformation of the steel bars, a special steel with a low coefficient of thermal expansion has to be used. For this purpose, steel containing 36% nickel is suitable. The cross-heads consist of normal steel. A dovetailed opening is located in the centre of each cross-head to fix the specimen when tensile stresses occur (Figs. 2a and 2b).

The cross-heads should be enlarged to the top by an angle of about 2° , to enable easy removal of the specimen. The two cross-heads must be fixed to the bars with prestressed screws of at least 30 mm in diameter. Additionally, the steel bars must be prestressed against the cross-heads in the longitudinal direction by screws (16 mm in diameter) and springs; the prestressing force

must be at least 40 kN. Thus, a displacement between the bars and cross-heads during the change from compression to tension will be prevented.

The formwork is made using a thermal insulating material, e.g. polystyrene with a thickness of 50 mm and 24 mm thick wood as a stabilizing element (Fig. 3).

Inside the formwork (next to the concrete specimen), a 0.2 mm thick copper plate is fixed on the polystyrene. This causes the heating of the specimen to be similar to that of a concrete member of about 50 cm in thickness and without any external heating. To enable additional heating or cooling within the thermal insulation, copper pipes (6 mm in diameter) are installed which are in contact with the copper plates. Water can be pumped through these pipes.

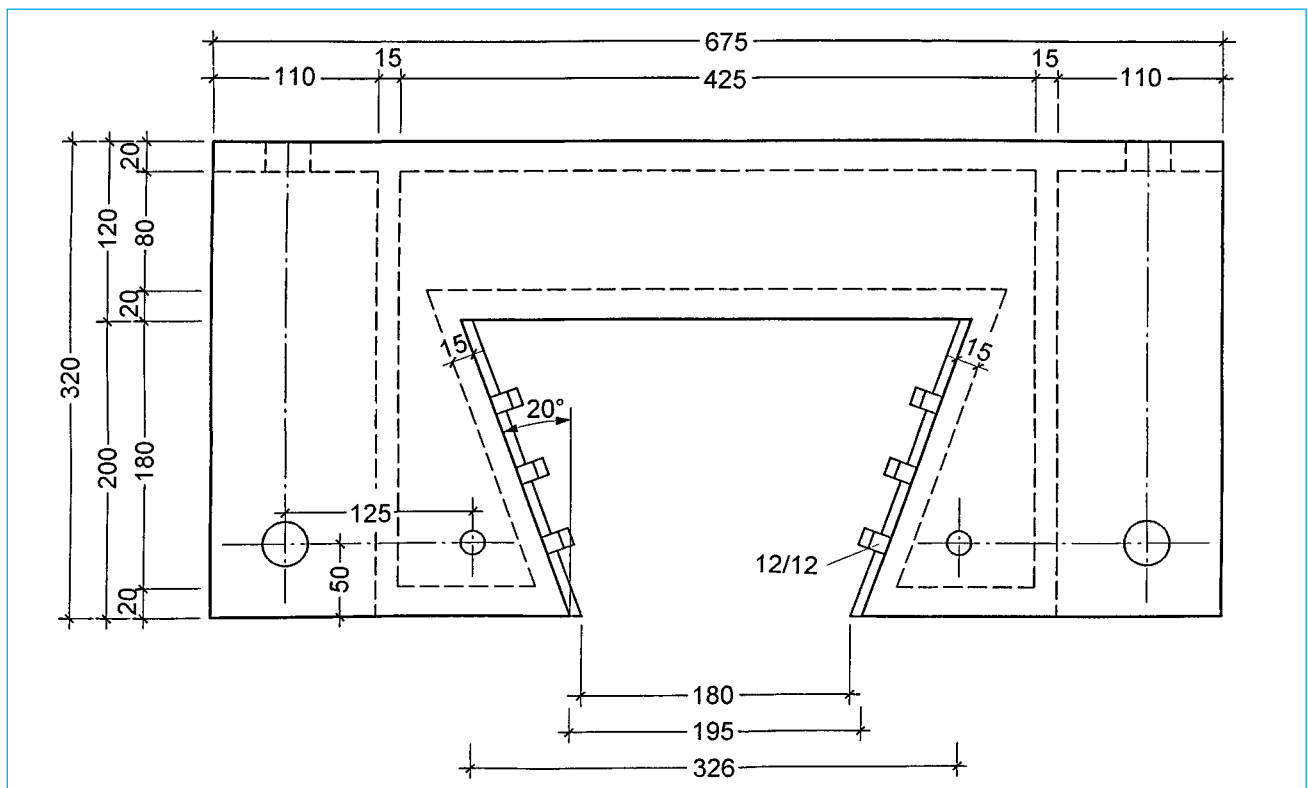

Fig. 2a - Cross-head: Detail plan.

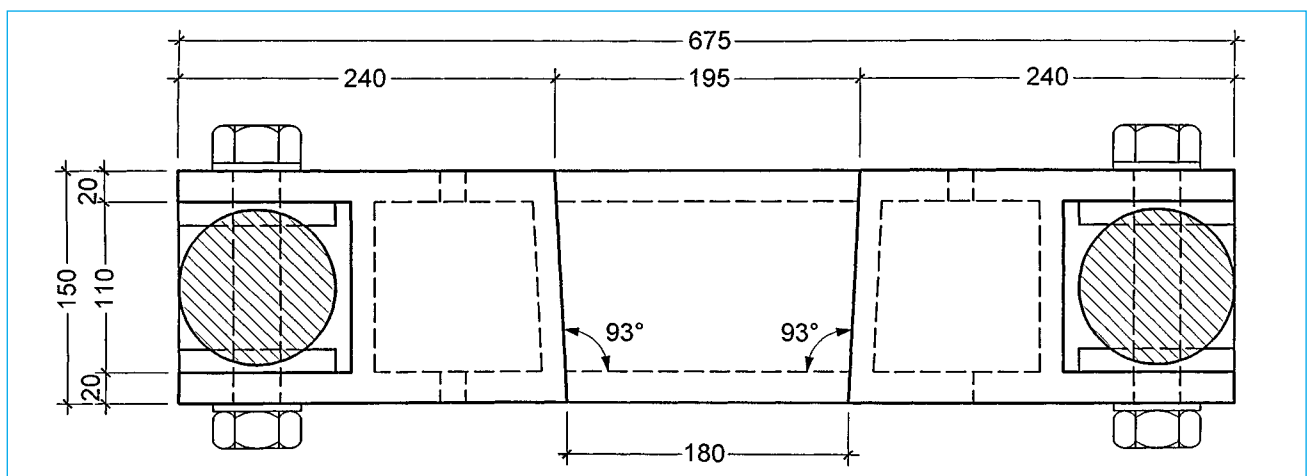

Fig. 2b - Cross-head: Cross-section.

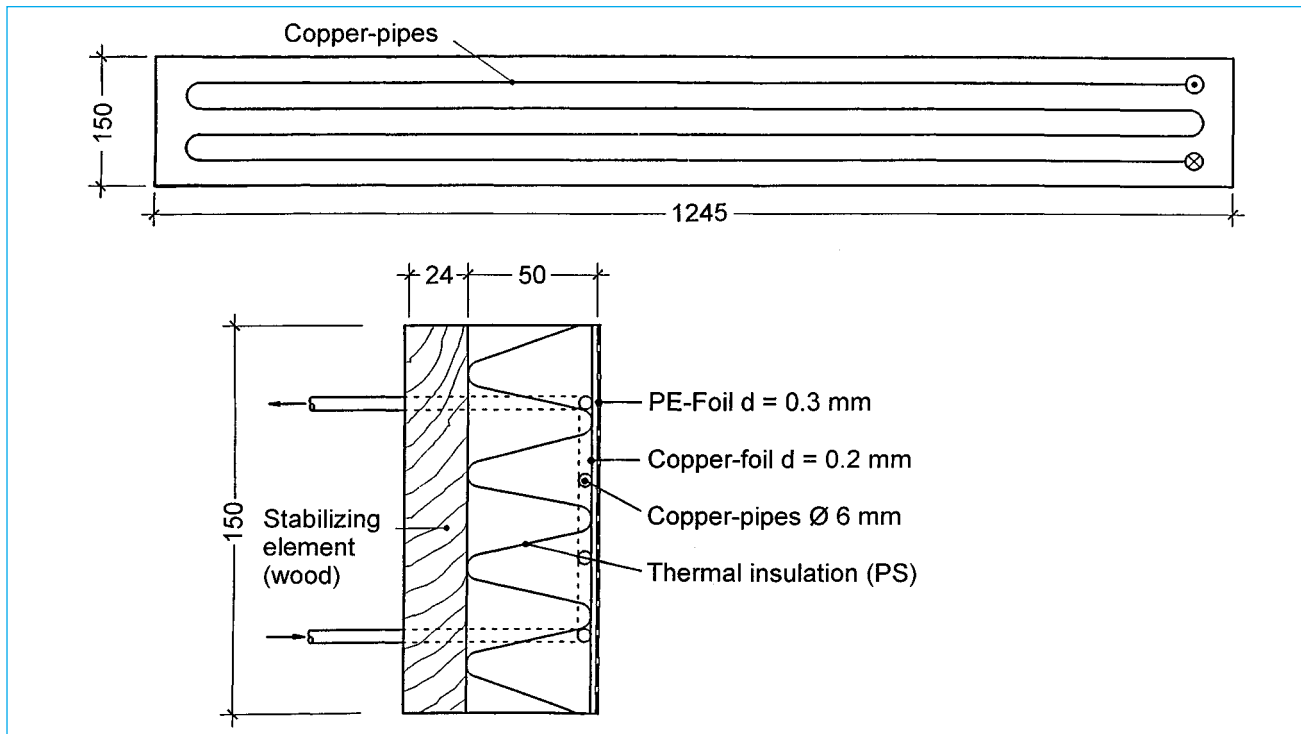

Fig. 3 – Formwork.

The 1.65 m long specimen is fixed within the dovetails of the cross-heads. To prevent notch stresses in the specimen near the cross-heads, the formwork must be formed in a sector of 200 mm in front of the cross-heads in such a way that the specimen is enlarged in a parabolic form continuously without any edge. Thus the specimen has a constant cross-section of $150 \times 150 \text{ mm}^2$ over a length of 0.85 m.

To prevent the specimen from drying out during the test, the formwork is wrapped additionally with a 0.3 mm thick polyethylene foil.

3.2 Measurements

During the test, the temperature in the centre of the specimen and the stresses in the specimen have to be measured continuously.

For temperature measurement, thermometers (*e.g.* PT 100) are installed in the specimen soon after casting and finishing of the fresh concrete. This requires only a small hole (maximum 3 mm in diameter) for the insertion of the thermometer (otherwise an artificial failure will be located).

For the determination of the stress within the specimen, strain gauges must be fixed on both of the longitudinal steel bars of the cracking frame in the form of a Wheatstone bridge. The elastic deformations of the steel bars due to the restraint force of the concrete specimen can then be measured. In view of the cross-section and the stiffness (modulus of elasticity) of the steel bars, the actual force (*i.e.* stress) in the specimen can be determined, because the force in the specimen is of the same value as that in the steel bars, however with the opposite sign.

Before a test is carried out in the cracking frame, the strain gauges have to be calibrated. This can be done with, for example, two steel bars between the two cross-heads which are connected with a loading cell and a screw. With the latter, the frame can be loaded under compression (*i.e.* tensile stress in the concrete beam).

4. PREPARATION OF THE CONCRETE SPECIMEN

Before the concrete is placed into the cracking frame, the bottom and the two sides of the formwork must be fixed at the frame. A joint of 2–3 mm between the cross-heads and the formwork must be present on each side, otherwise the deformations of the specimen are additionally restrained in an uncontrolled way. These joints have to be sealed with a plastic material, *e.g.* silicone. In the same way, the joints between the formwork elements have to be sealed. The fresh concrete is placed directly into the cracking frame. The temperature of the fresh concrete should be $20 \pm 1^\circ\text{C}$. After compaction with an internal vibrator, the surface is finished in the conventional manner. The surface is covered by sticking a polyethylene sheet to the sides of the formwork and the cross-heads. The open ends of the dovetailed cross-heads are then connected with a steel plate ($40 \times 10 \text{ mm}^2$), each with screws on the upper surface. This prevents opening of the cross-heads due to tension in the specimen. The same plates must be screwed onto the bottom of the cross-heads before the lower formwork is fixed to the frame.

The thermometer is then installed in the centre of the specimen. Finally, the thermally-insulated upper formwork is fixed onto the specimen.

5. STORAGE CONDITIONS

The tests shall be performed at an ambient temperature of $20 \pm 2^\circ\text{C}$ and a relative humidity of $65 \pm 5\%$.

6. PROCEDURE FOR THE STANDARD TEST

After casting, the specimen for the standard test remains in the thermally-insulated formwork under semi-adiabatic conditions for 96 hours without any artificial thermal treatment. Thus the temperature increase in the concrete specimen is due only to the heat of hydration in connection with the thermal insulation. During this period, the temperature and the restraint stresses in the specimen have to be measured continuously.

After 96 hours, the specimen has cooled down close to the ambient temperature. If at this time the concrete has not yet been cracked, the specimen must be cooled down artificially. The cooling rate should be 1 ± 0.1 K/h. For this purpose, cooling water is pumped through the pipes within the formwork. When the specimen has been cracked (this can be established by the sudden drop of the measured stresses to nearly zero), the test can be terminated.

With this standard test, the cracking tendency of various concretes can be compared under identical thermal and restraining conditions.

In order to remove the cracked specimen, the concrete is pulled out from the cross-heads using suitable hydraulic equipment. Care must be taken that the frame is not excessively bent or twisted when pulling out the specimen.

7. CONCRETE MIX FOR STANDARD TEST

Normally, the cracking tendency of concretes has to be assessed at the beginning of a concrete project, when the exact mix composition is not yet known. Thus, the cracking tendency of the individual components (*e.g.* various cements) must be compared. For this purpose a constant mix composition must be used. On the basis of present experience the following mix composition has proved to be appropriate for standard tests:

Aggregate: A/B 32 mm according to DIN 1045
Cement: 340 kg/m³ ¹⁾
Water: 162 kg/m³
Consistency: F 3 according to ENV 206 regulated by the addition of superplasticizers

8. TEMPERATURE CONTROLLED TEST FOR MASS CONCRETE

In some special cases, *e.g.* for the simulation of the temperature in mass concrete members several meters thick, it may be necessary to regulate the temperature in the specimen. For this purpose, a separate calorimeter test has to be carried out beforehand. With these results, the temperature behaviour within the simulated member can be calculated. During the cracking test, the calculated variation in temperature is applied to the specimen using a thermostat. Apart from this, the test can be carried out as in the standard test. However, in this case the temperature and stress curves, as well as the characteristic values, *e.g.* the cracking temperature, are different from the results obtained in standard tests.

For the comparison of different concrete mixes, the standard test gives a good indication even for mass concrete. This is because the development of elastic properties and of the relaxation on the first day is decisive for thermal stresses. During the first day, the temperature in both tests differs only slightly.

9. TEST RESULTS

From the recorded data the following characteristic values should be extracted and documented in a test report:

- Temperature of the fresh concrete
- First zero stress temperature
- Age at which the first zero stress temperature has been reached
- Maximum in compressive stress during heating
- Age at which the maximum compression has been reached
- Maximum temperature
- Age at which the maximum temperature has been reached
- Second zero stress temperature
- Age at which second zero stress temperature has been reached
- Temperature at an age of 96 hours
- Stress at an age of 96 hours
- Maximum tensile stress at the time of cracking
- Temperature at the time of cracking
- Age at cracking.

Additionally, it is recommended to plot the curves for stress and temperature development.

1) The cement content has to be reduced appropriately when pozzolanic admixtures are used.